



### ĮGYVENDINTI PRAMONINIAI OBJEKTAI

- 6,500 t, Lietuva, 2018 m., 4 x 1500 t bokštai, 40 t/val. džiovykla, konvejerinė ir valymo įranga iki 100 t/val
- 37,500 t, Danija, 2018 m., 3 x 12,500 t bokštai, 80 t/val. džiovykla, konvejerinė ir valymo įranga iki 200 t/val
- 18,000 t, Lietuva, 2015-2016 m., 6 x 3000 t bokštai, 80 t/val. džiovykla, konvejerinė ir valymo įranga iki 220 t/val
- 23,400 t, Danija, 2012-2014, 3 x 7800 t bokštai, bokštinė cilindro formos 150 t/val. džiovykla, konvejerinė įranga.
- 15,600 t, Rumunija, 2015 m., 4 x 3900 t bokštai, konvejerinė įranga.
- 21,600 t, Rumunija, 2009-2015 m., 6 x 3600 t bokštai, konvejerinė įranga.
- 25,200 t, Rumunija, 2010-2015 m., 7 x 3600 t, konvejerinė, džiovinimo įranga.
- 30,000 t, Rusija, 2016 m., 2 x 8000, 2 x 5000, 6x bunkeriniai bokštai.

**Projektas:**

4 bokštai Sukup x 1,500 t  
Konvejerinė įranga iki 100  
t/val.

Džiovykla iki 40t/val.

**Viso talpa: 6,500 t**

Gamintojas: Sukup,  
Damas, Scandia.

Objekto vieta: Lietuva

Montavimo rangovas: UAB  
„Inter-Silo“

Montavimo data: 2018

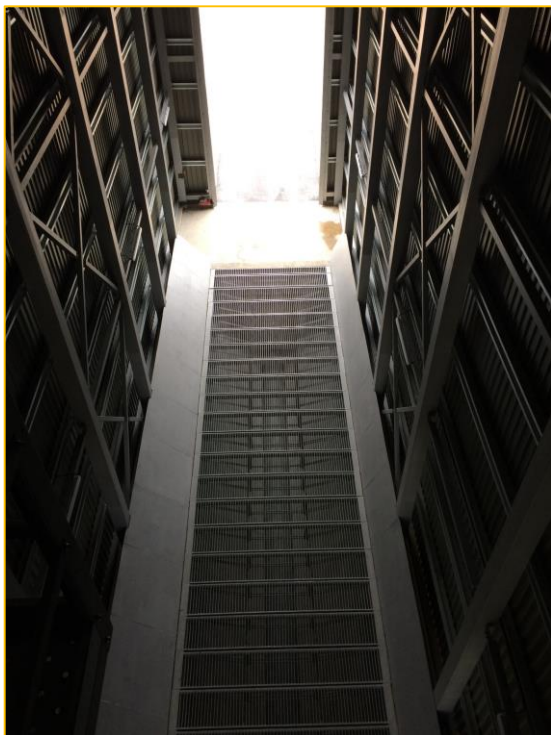
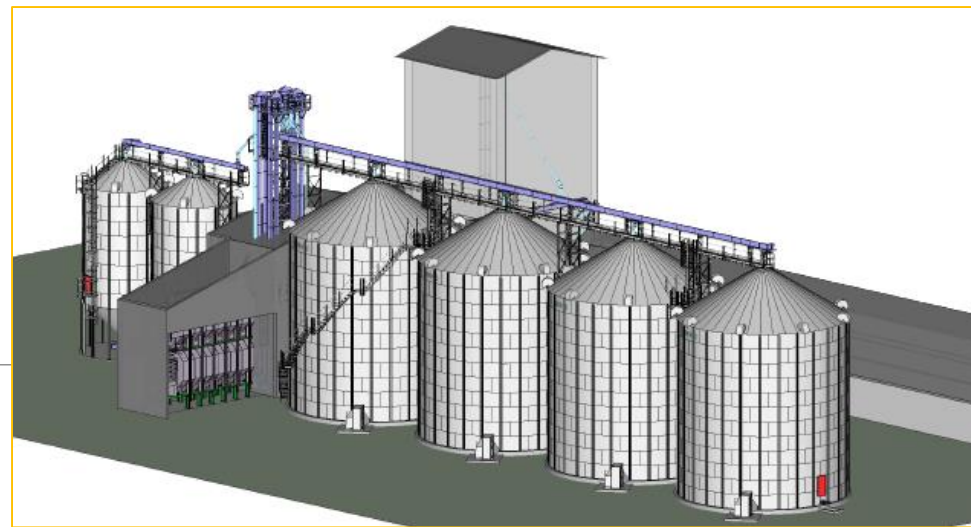



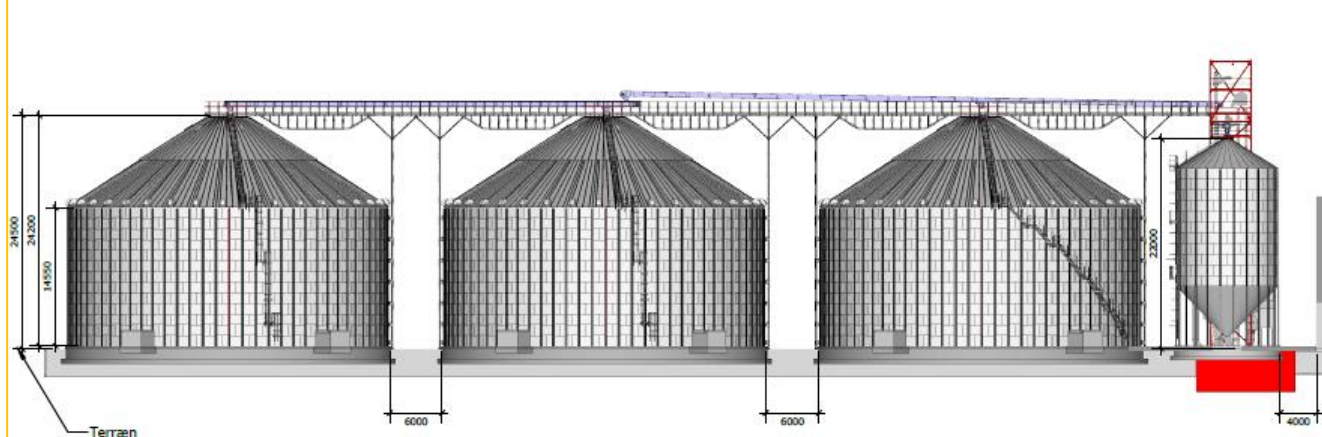
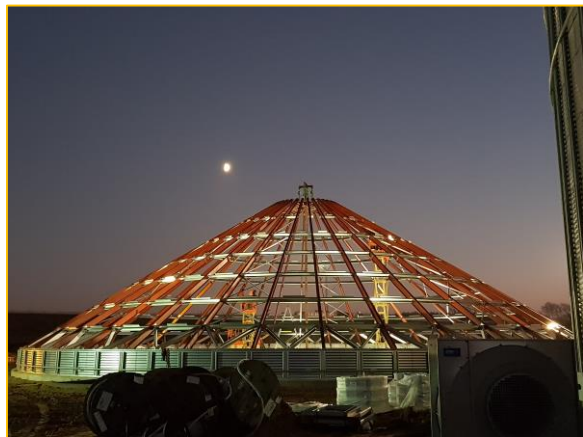
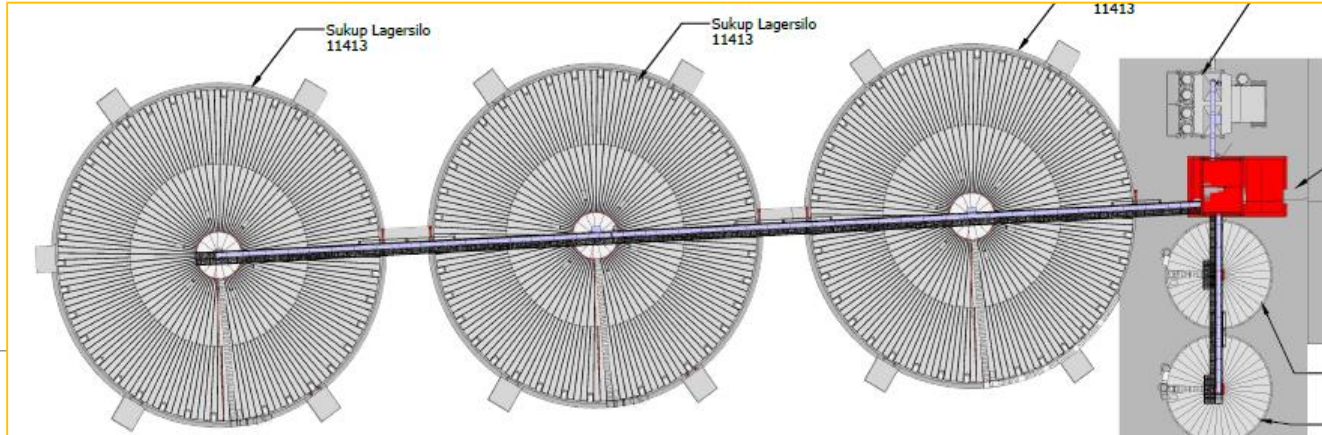

**Projektas:** 3 bokštai Sukup x 12,500 t

Konvejerinė įranga iki 200 t/val.,

Džiovykla iki 80 t/val.

**Viso talpa: 37,500 t**

Gamintojas: Sukup, Lackemeier

Objekto vieta: Danija

Užsakovas: Sukup-Europe A/S

Montavimo data: 2018

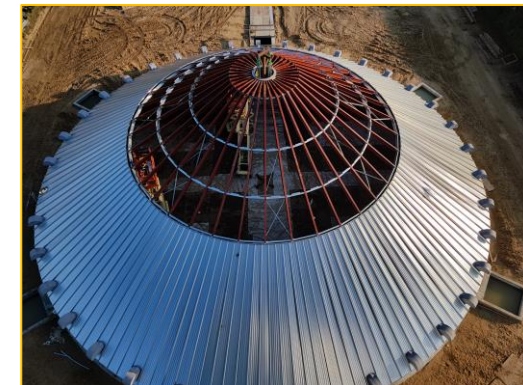



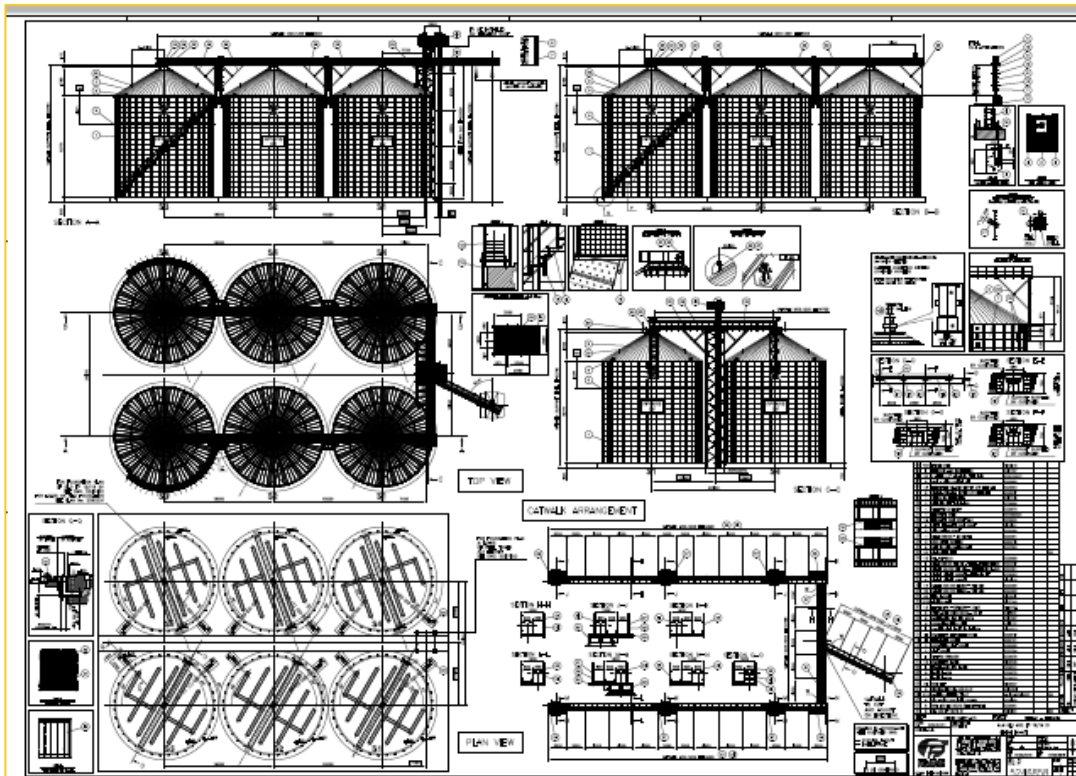

**Projektas:** 6 bokštai Frame x 3000 t +  
sėklų fabrikas, konvejerinė įranga iki  
220 t/val., džiovykla iki 80 t/val.

**Viso talpa:** 18,000 t

Gamintojas: Skiold, Frame.

Objekto vieta: Lietuva

Montavimo rangovas: UAB „Inter-Silo“

Užsakovas: Skiold A/S

Montavimo data: 2016

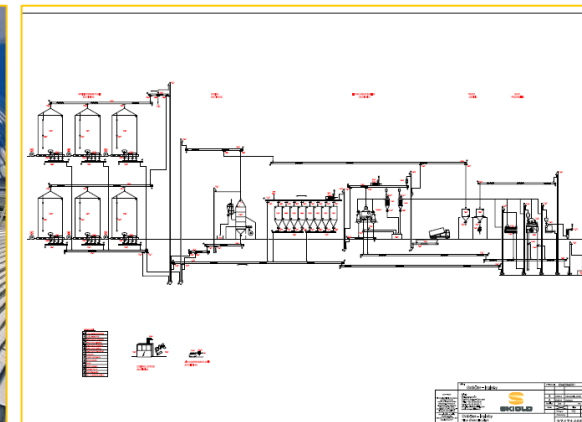



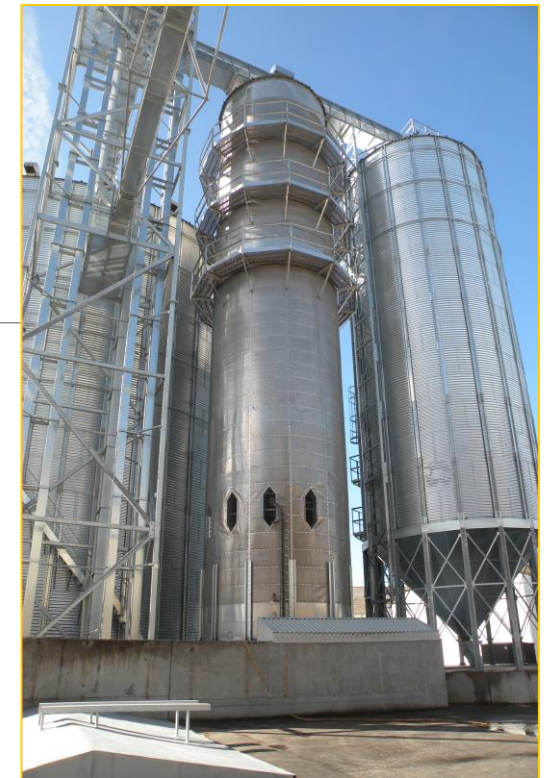
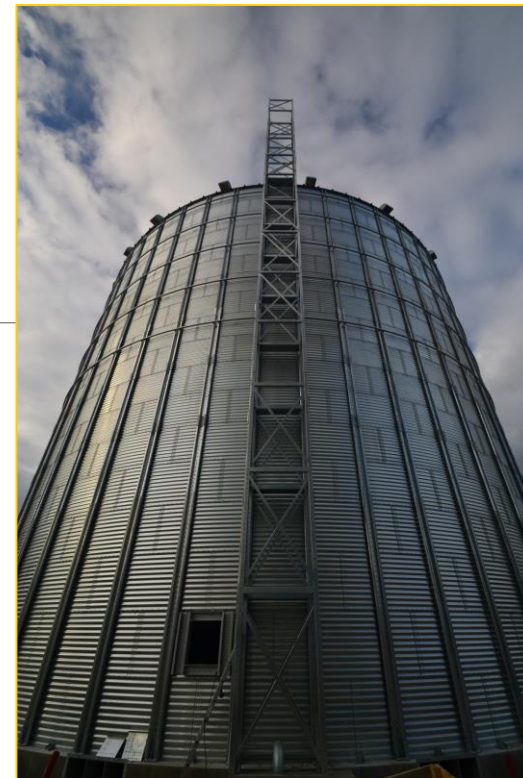
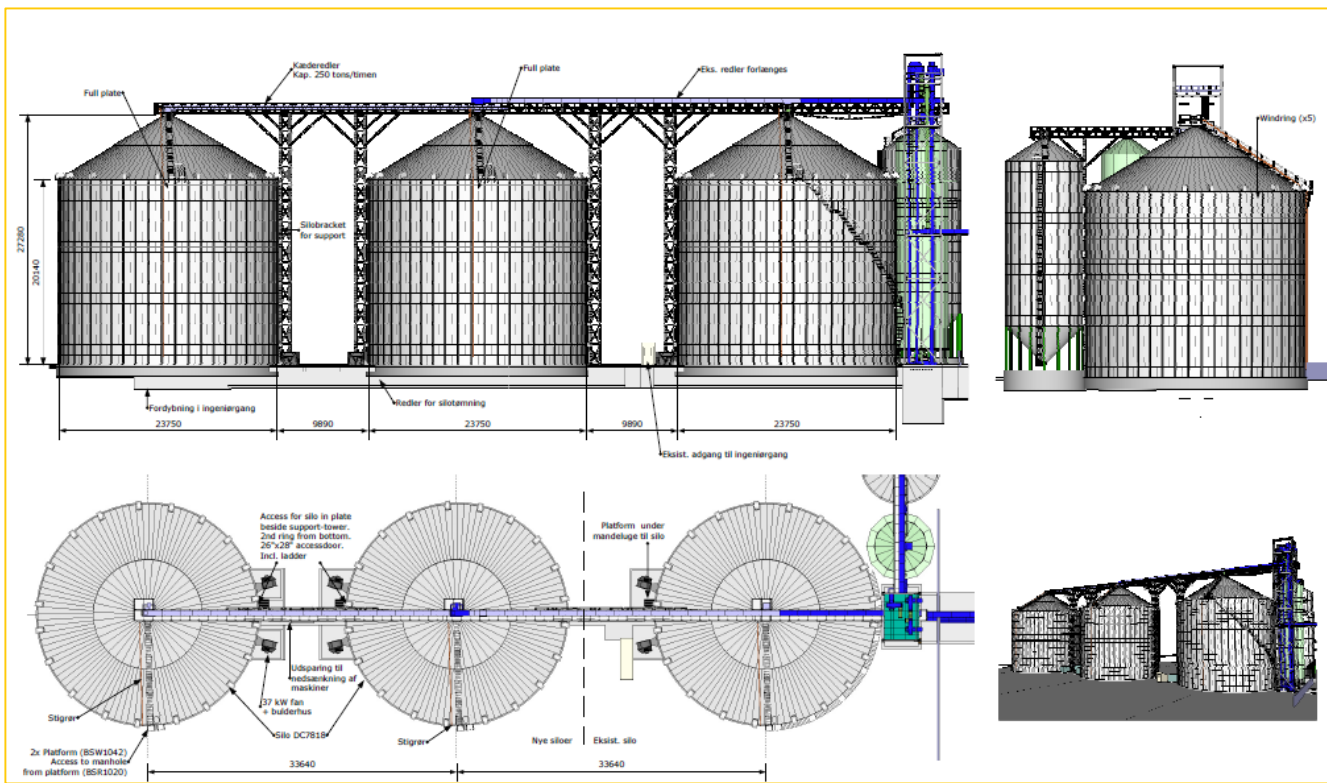

**Projektas:** 3 bokštai x 7800 t +  
 konvejerinė įranga Skandia, bokštinė  
 džiovykla Sukup 150 t/val.  
**Viso talpa:**23,400 t  
 Gamintojas: Sukup, Skandia  
 Objekto vieta: Danija  
 Montavimo rangovas: UAB „Inter-Silo“  
 Užsakovas: Dancorn A/S  
 Montavimo data: 2014





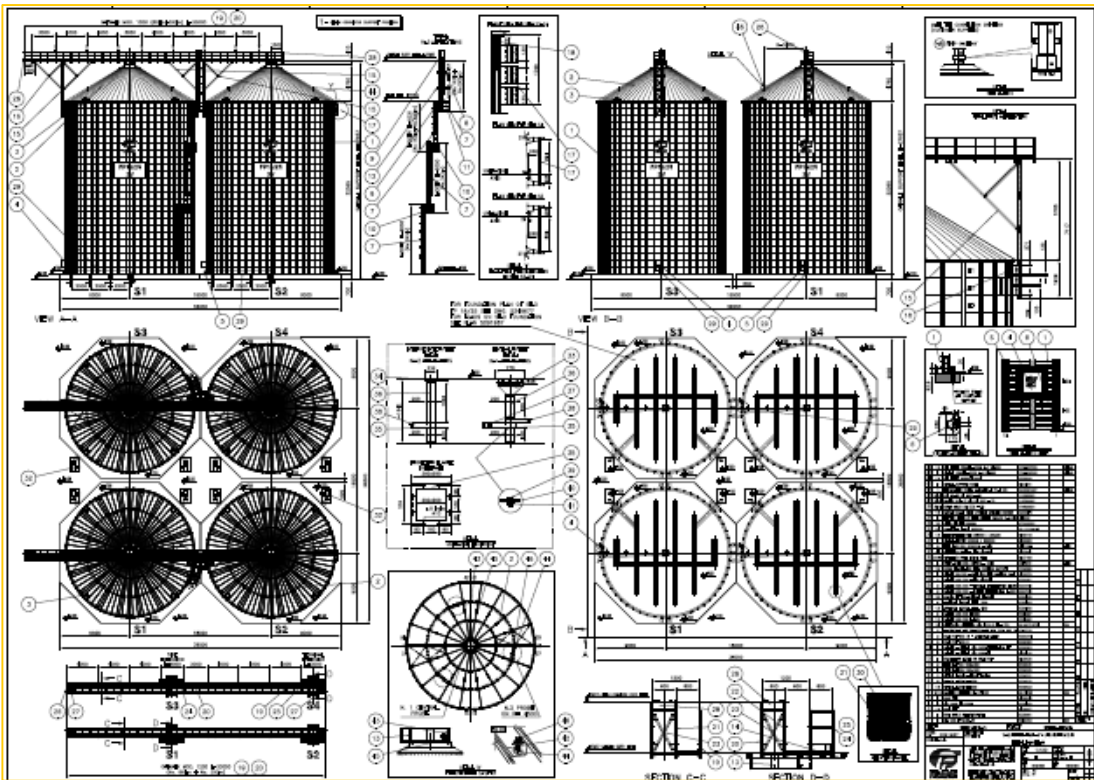

**Projektas:** 4 sandėliavimo bokštai x

3900 t + konvejerinė įranga

**Viso talpa:** 15,600 t

Gamintojas: Frame

Objekto vieta: Rumunija

Montavimo rangovas: UAB „Inter-Silo“

Užsakovas: Skiold A/S

Montavimo data: 2015 m

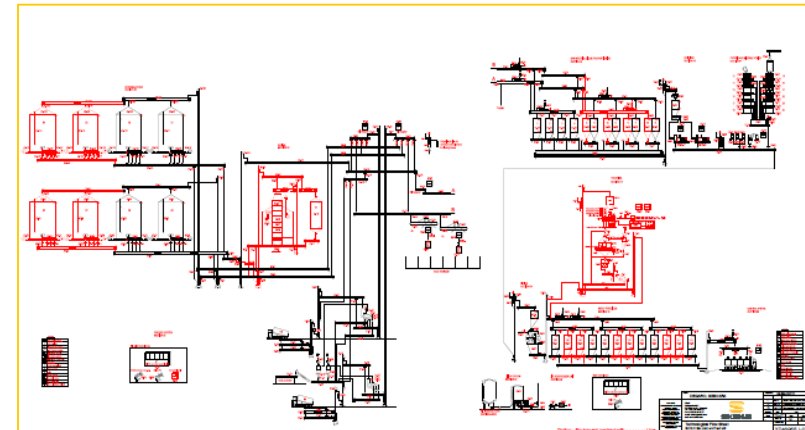



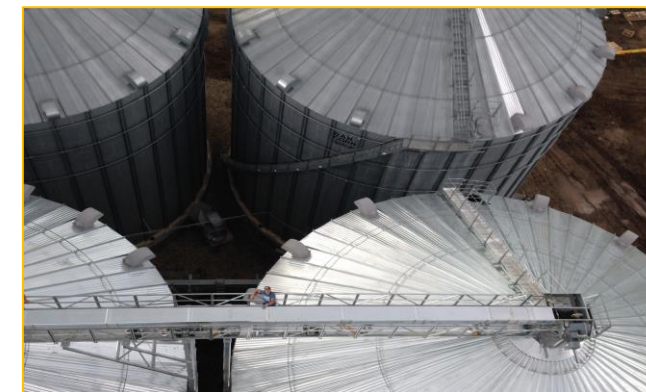
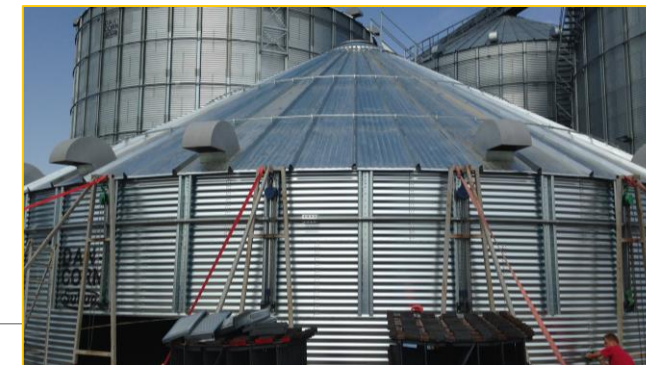
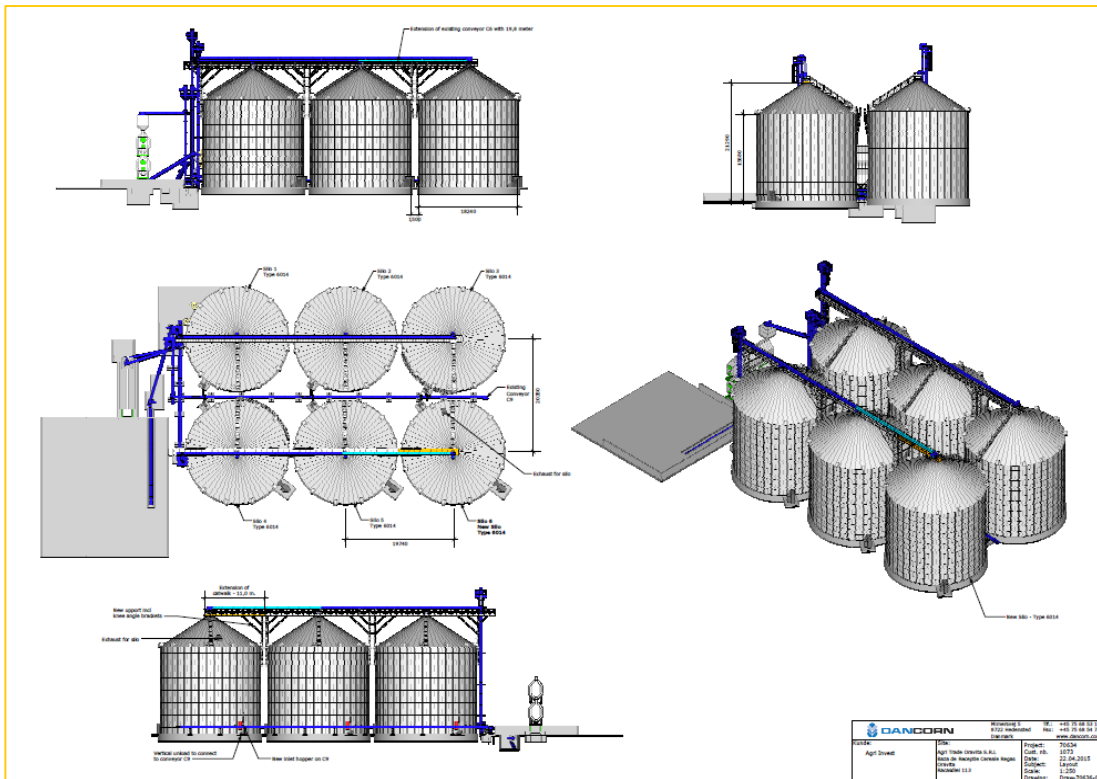

**Projektas:** 6 bokštai 6014 x 3600 t +

konvejerinė įranga Skandia

**Viso talpa:** 21,600 t

Gamintojas: Sukup, Skandia

Objekto vieta: Rumunija

Montavimo rangovas: UAB „Inter-Silo“

Užsakovas: Dancorn A/S

Montavimo data: 2009-2015 m

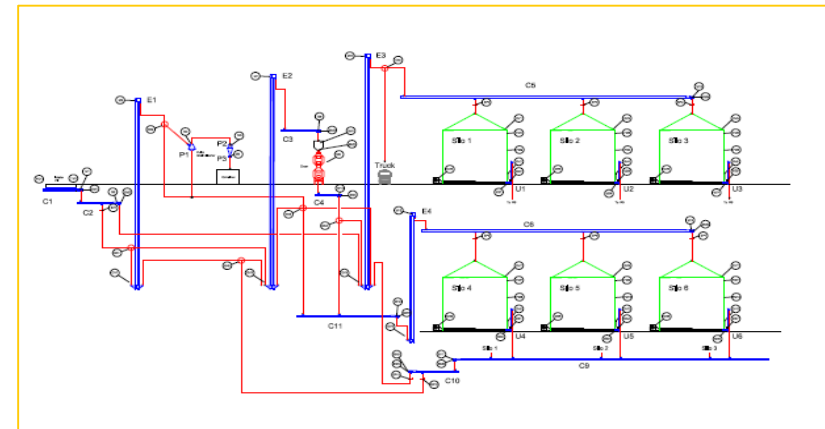



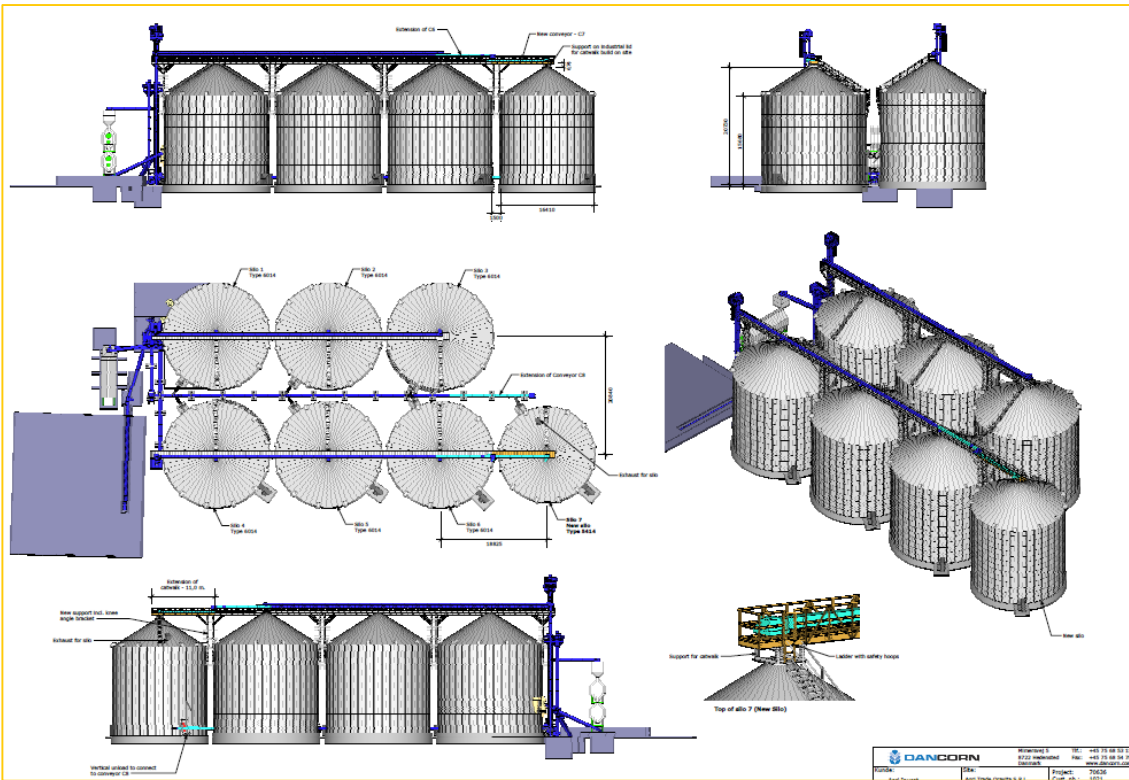

**Projektas:** 7 bokštai 6014 x 3600 t +

konvejerinė įranga Skandia

**Viso talpa:** 25,200 t

Gamintojas: Sukup, Skandia

Objekto vieta: Rumunija

Montavimo rangovas: UAB „Inter-Silo“

Užsakovas: Dancorn A/S

Montavimo data: 2010-2015 m

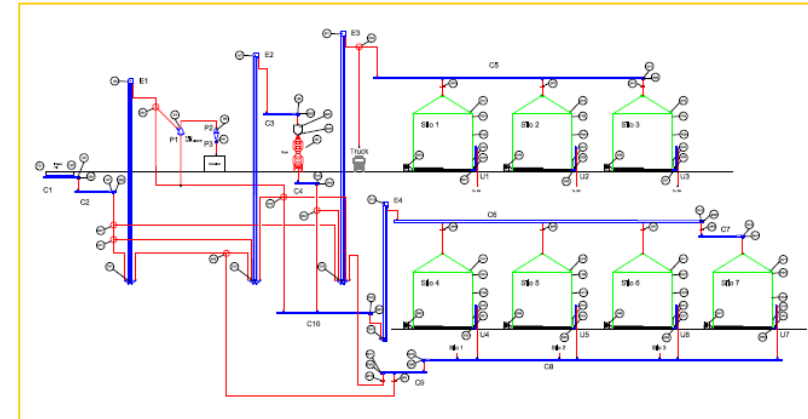



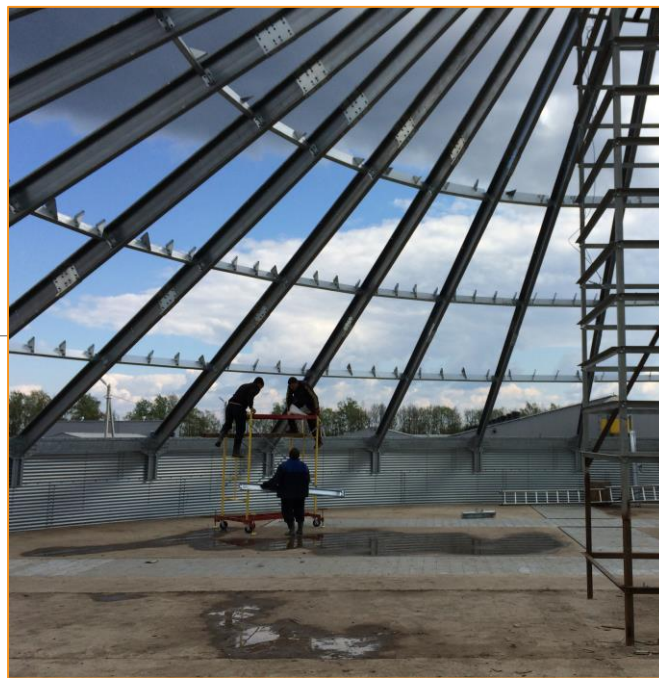
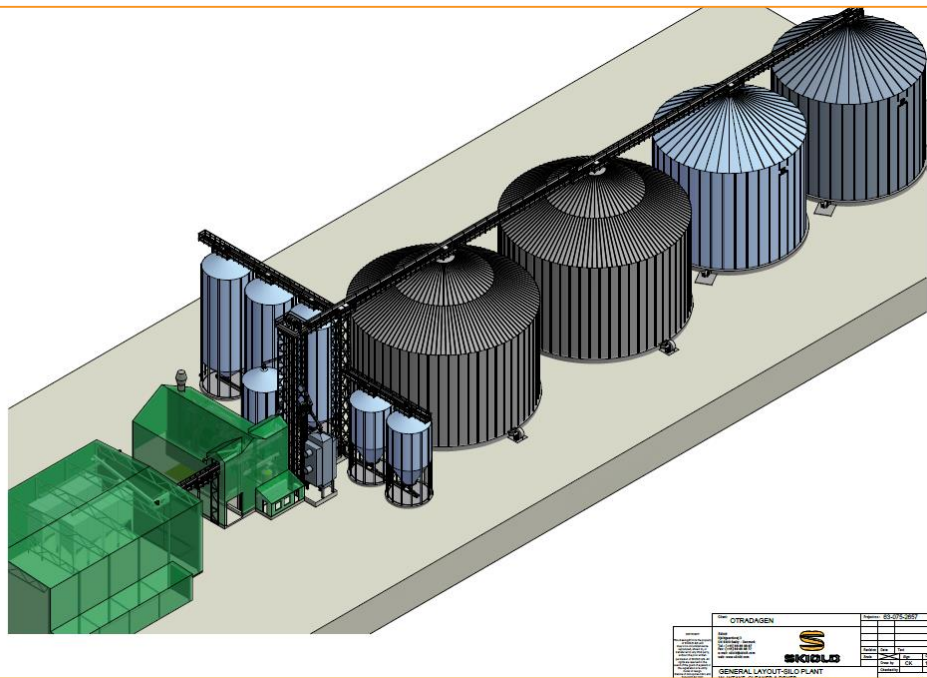

**Projektas:**

**Viso talpa: apie 30,000 t**

**2 bokštai x 8000 t, 2 bokštai po 5000 t, 6**

**bunkeriniai bokštai**

Gamintojas: Skiold, Frame

Objekto vieta: Rusija

UAB „Inter-Silo“ vykdo montavimo

priežiūros ir organizavimo darbus

Užsakovas: Skiold A/S

Montavimo data: 2016 m

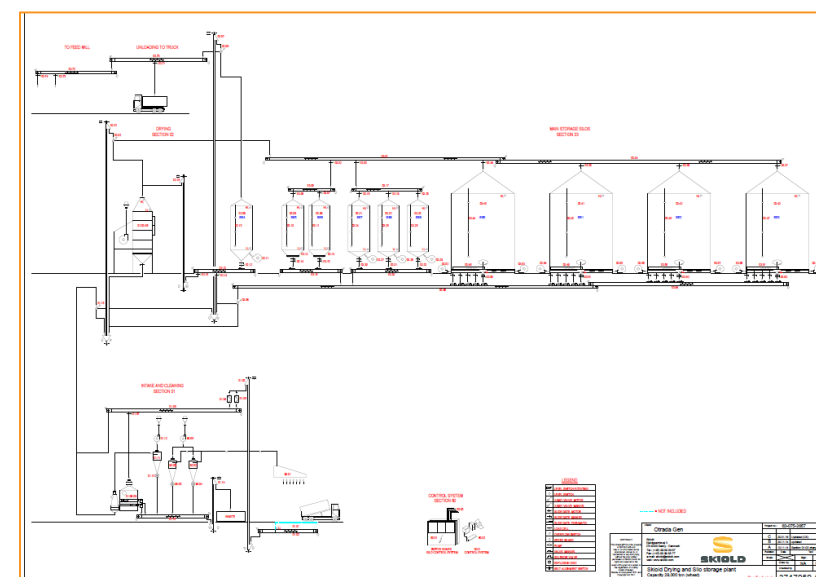



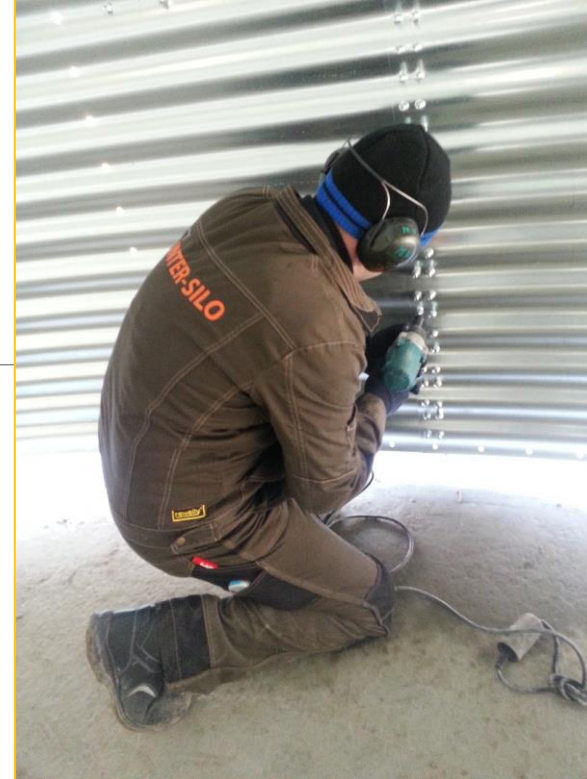





**INTER-SILO**



**THE  
UNBREAKABLES**

[www.inter-silo.com](http://www.inter-silo.com)